

STEER Series

Product Description:

The STEER series is one of AGL's most versatile units; able to be utilized as a high bay, post top or food processing fixture. The STEER has a sleek, modern look while also providing up to 160 lm/W and has a waterphobic finish, making it a great option as a high bay or post top fixture. The STEER is also available with an IP69K rating and a steam/high pressure water spray resistant finish making it a viable option in the food processing or pharmaceutical industry.

Features:

- **Application:** LED High Bay/Post Top/Food Processing
- **Warranty:** 5 Years
- **LED Driver:** Meanwell
- **LED Source:** Lumileds
- **Operating Temperature:** -40°F ~+ 131°F

Technical Data:

Certifications	ETL
CRI	≥ 70/80
Voltage	100-277V
CCT	2700K-6500K
Beam Angle	60°/90°/120°
Power Factor	>0.95
IP Rating	IP66 for High Bay/Post Top IP69K for Food Processing
Mounting Options	Hanging Ring (HB/FP only) Pole Mount (PT only)



STEER High Bay (HB)

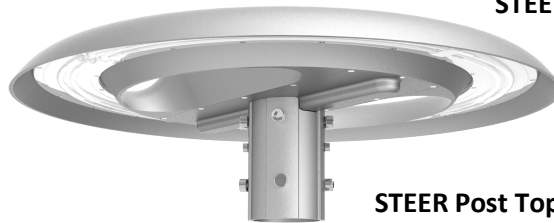

STEER Post Top (PT)



STEER Food Processing (FP - White Only)

Specifications:

Fixture Model	Total Lumens*	Efficacy	Dimensions (HighBay & FP/inches)	Dimensions (Post Top/inches)	Beam Angle
STEER-30W	4,968.2 lm	165.6 lm/W	Φ14.9" x 4.44"	Φ14.9" x 6.39"	60°/90°/120°
STEER-50W	8,075.8 lm	161.5 lm/W			
STEER-80W	13,072.1 lm	163.4 lm/W			
STEER-100W	16,486.7 lm	164.8 lm/W			
STEER-150W	24,362.8 lm	162.4 lm/W			
STEER-200W	32,567.6 lm	162.8 lm/W	Φ19.6" x 4.64"	Φ19.6" x 6.61"	
STEER-240W	39,021.7 lm	162.6 lm/W			

*Lumens measured @5000K/90°

Photometrics

STEER-100W/60°

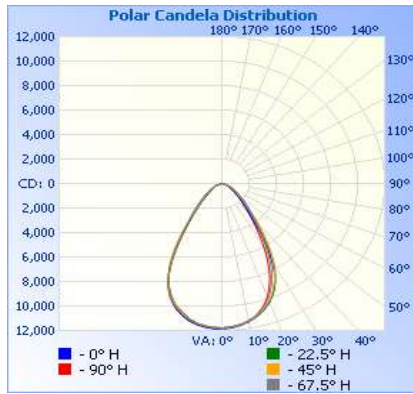

	Illuminance at a Distance		
	Center Beam fc	Beam Width	
9.7ft	125 fc	12.8 ft	12.2 ft
19.3ft	31.7 fc	25.5 ft	24.2 ft
29.0ft	14.0 fc	38.3 ft	36.3 ft
38.7ft	7.88 fc	51.2 ft	48.5 ft
48.3ft	5.06 fc	63.9 ft	60.5 ft
58.0ft	3.51 fc	76.7 ft	72.7 ft

■ Vert. Spread: 66.9°
■ Horiz. Spread: 64.1°

Dimensions

STEER-30W to 150W (High Bay/Food Processing)

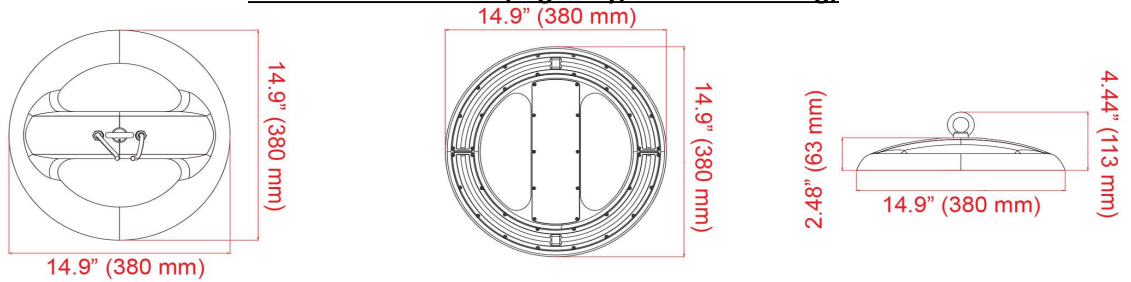

STEER-200W to 240W (High Bay/Food Processing)

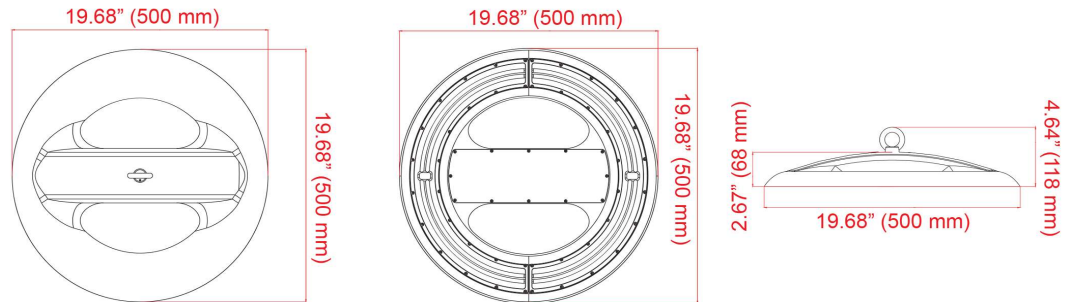

STEER-30W to 150W (Post Top)

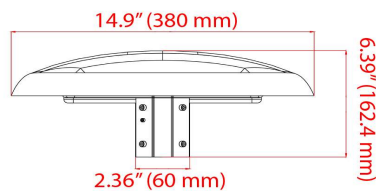

STEER-200W to 240W (Post Top)

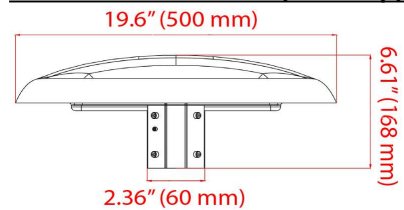

Ordering Guide:

STEER-150W	FP-WH	90°	Hanging Ring	40K	
Wattage: 30W 50W 80W 100W 150W 200W 240W	Style & Color: HB-GR: High Bay in Grey PT-GR: Post Top in Grey FP-WH: Food Processing in White	Beam Angle: 60° 90° 120°	Mounting: Ceiling (HB/FP only) Hanging Ring (HB/FP only) Pole Mount (PT only)	CCT: 27K 30K 40K 50K 65K	Additional Accessories: MSa: Motion Sensor (on/off) MSb: Motion Sensor (1-10V dimming) MSc: Motion Sensor (1-10V dimming + remote control)