

## NEPTUNE Series

### Product Description:

The NEPTUNE Series is the 1st generation in Roadway Luminaires from All Green Lighting, Inc. This luminaire is known for its reliability, and has proven to be ideal for applications in roadway / street light, and area lighting. The NEPTUNE is available in a wide range of wattages, color temperatures, and options - making it versatile for specific applications. Calculated life span of over 100,000 hours.



### Features:

- **Operating voltage:** 100-277V or 347-480V
- **Power Factor:** > 0.99 at full load
- **Total Harmonic Distortion:** < 20% at full load
- **CRI:** >70
- **CCT:** 2700K - 5700K
- **IP66 rated.**
- **Surge Protection:** Integral 10kV surge suppression protection standard. Tested in accordance with ANSI C62.41.2
- **UL listed**
- **Vibration:** Certified to ANSI C136.31-2001 3G vibration standards.
- **Finish:** An ultra-durable powder coat finish provides excellent resistance to corrosion, ultraviolet degradation and abrasion. Tested in accordance with ASTM Standard B 117 (3,000 hour salt fog spray test).
- **RoHS Dark Sky Compliant**
- **Mounting:** Slipfitter (fits 1.66" or 2.38" O.D. tenon). Leveling adjustment in increments.
- **Dimming:** 0-10V dimming capabilities (standard), controls by others.
- **Warranty:** 5 year standard warranty on components.
- **Operating Temperature:** -40°F ~ 140°F
- **LED Source:** CREE Light Engine
- **Housing Material:** Die cast aluminum with tool-less entry
- **EPA (25W-100W):** 0.5 ft<sup>2</sup> , **EPA (120W-200W):** 0.8 ft<sup>2</sup>

### Dimensions: 25W ~ 100W

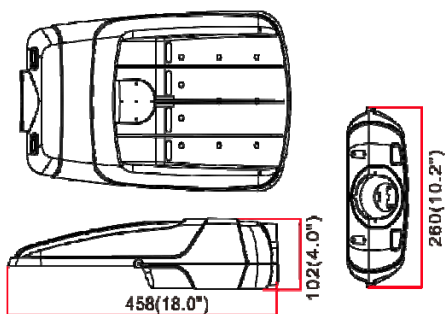

EPA: 0.05m<sup>2</sup>  
(0.5 ft<sup>2</sup>)  
Weight: 2.8 kgs  
(6.2 lbs)

### 120W ~ 240W

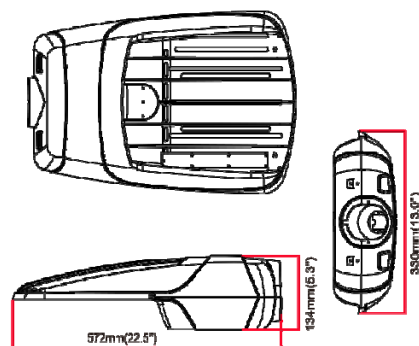

EPA: 0.08m<sup>2</sup>  
(0.8 ft<sup>2</sup>)  
Weight: 6.5 kgs  
(14.5 lbs)

## Lumen Chart:

Model-Watts	Current	Beam Type	2700K				3000K				3500K				4000K				5700K			
			lum	lpw	b	u g	lum	lpw	b	u g	lum	lpw	b	u g	lum	lpw	b	u g	lum	lpw	b	u g
NEPTUNE-25W	0.7A	T2	2,773	110	1	0 1	2,919	116	1	0 1	2,948	117	1	0 1	2,825	113	1	0 1	3,201	128	1	0 1
		T3	2,791	111	1	0 1	2,938	117	1	0 1	2,967	118	1	0 1	2,866	114	1	0 1	3,225	129	1	0 1
		T4	2,816	112	1	0 1	2,964	118	1	0 1	2,994	119	1	0 1	2,704	108	1	0 1	3,254	130	1	0 1
		T5	2,644	105	2	0 2	2,783	111	2	0 2	2,811	112	2	0 2	2,823	112	2	0 2	2,906	116	2	0 2
NEPTUNE-40W	0.75A	T2	4,694	117	1	0 1	4,940	123	1	0 1	4,990	124	1	0 1	4,852	121	1	0 1	5,260	131	2	0 2
		T3	4,654	116	1	0 1	4,899	122	1	0 1	4,948	123	1	0 1	4,706	117	1	0 1	5,029	125	1	0 1
		T4	4,593	114	1	0 1	4,835	120	1	0 1	4,883	122	1	0 1	4,259	106	1	0 1	4,962	124	1	0 1
		T5	4,462	111	3	0 3	4,697	117	3	0 3	4,744	118	3	0 3	4,745	118	3	0 3	4,932	123	3	0 3
NEPTUNE-65W	1.15A	T2	6,422	98	2	0 2	6,761	104	2	0 2	6,828	105	2	0 2	6,357	97	2	0 2	7,622	117	2	0 2
		T3	6,489	99	2	0 2	6,831	105	2	0 2	6,899	106	2	0 2	6,889	105	2	0 2	7,545	116	2	0 2
		T4	6,467	99	2	0 2	6,807	104	2	0 2	6,875	105	2	0 2	6,821	104	2	0 2	7,518	115	2	0 2
		T5	6,084	93	3	0 3	6,404	98	3	0 3	6,468	99	3	0 3	6,684	102	3	0 3	6,962	107	3	0 3
NEPTUNE-80W	0.85A	T2	8,650	108	3	0 3	9,320	116	3	0 3	9,409	117	3	0 3	9,275	115	2	0 2	10,161	127	2	0 2
		T3	8,889	111	2	0 2	9,357	116	2	0 2	9,451	118	2	0 2	9,407	117	2	0 2	9,801	122	2	0 2
		T4	8,921	111	2	0 2	9,390	117	2	0 2	9,484	118	2	0 2	8,610	107	2	0 2	9,836	122	2	0 2
		T5	8,458	105	3	0 3	8,903	111	3	0 3	8,992	112	3	0 3	8,951	111	3	0 3	9,312	116	3	0 3
NEPTUNE-100W	1.0A	T2	9,938	99	3	0 3	10,464	104	3	0 3	10,566	105	3	0 3	10,886	108	3	0 3	11,583	115	3	0 3
		T3	9,906	99	2	0 2	10,431	104	2	0 2	10,531	105	2	0 2	10,813	108	2	0 2	11,392	113	2	0 2
		T4	10,021	100	3	0 3	10,548	105	3	0 3	10,653	106	3	0 3	10,937	109	2	0 2	11,524	115	2	0 2
		T5	9,539	95	4	0 4	10,041	100	4	0 4	10,141	101	4	0 4	10,075	100	4	0 4	10,788	107	4	0 4
NEPTUNE-120W	0.7A	T2	11,949	99	3	0 3	12,578	104	3	0 3	12,704	105	3	0 3	13,169	109	3	0 3	13,779	114	3	0 3
		T3	12,094	100	2	0 2	12,730	106	2	0 2	12,857	107	2	0 2	13,250	110	3	0 3	13,705	114	3	0 3
		T4	12,143	101	2	0 2	12,782	106	2	0 2	12,910	107	2	0 2	13,305	110	3	0 3	13,782	114	3	0 3
		T5	12,453	103	3	0 3	13,108	109	3	0 3	13,229	110	3	0 3	13,748	114	3	0 3	14,181	118	4	0 4
NEPTUNE-150W	1.0A	T2	15,930	106	3	0 3	16,770	111	3	0 3	16,936	112	3	0 3	16,987	113	3	0 3	18,446	122	3	0 3
		T3	15,930	106	3	0 3	16,768	111	3	0 3	16,936	112	3	0 3	17,439	116	3	0 3	18,253	121	3	0 3
		T4	15,699	104	3	0 3	16,525	110	3	0 3	16,890	112	3	0 3	17,184	114	3	0 3	17,987	119	3	0 3
		T5	16,371	109	4	0 4	17,233	114	4	0 4	17,405	116	4	0 4	17,148	114	4	0 4	18,494	123	4	0 4
NEPTUNE-180W	0.7A	T2	16,228	90	3	0 3	17,083	94	3	0 3	17,253	95	3	0 3	18,543	103	3	0 3	19,801	110	3	0 3
		T3	16,191	89	3	0 3	17,058	94	3	0 3	17,213	95	3	0 3	17,989	99	3	0 3	19,220	106	3	0 3
		T4	16,358	90	3	0 3	17,219	95	3	0 3	17,391	96	3	0 3	15,312	85	3	0 3	19,419	107	3	0 3
		T5	16,516	91	4	0 4	17,385	96	4	0 4	17,559	97	4	0 4	18,492	102	4	0 4	19,947	110	4	0 4
NEPTUNE-240W	1.0A	T2	20,631	85	3	0 3	21,730	90	3	0 3	21,934	91	3	0 3	24,376	101	3	0 3	26,375	109	4	0 4
		T3	20,655	86	3	0 3	21,742	90	3	0 3	21,959	91	3	0 3	24,838	103	3	0 3	25,915	107	3	0 3
		T4	20,492	85	3	0 3	21,570	89	3	0 3	21,786	90	3	0 3	20,470	85	3	0 3	25,709	107	3	0 3
		T5	21,148	88	4	0 4	22,261	92	4	0 4	22,484	93	4	0 4	24,473	101	5	0 5	26,806	111	5	0 5

Lumen values are from photometric tests performed in accordance with IESNA LM-79-08. Data is representative of the configuration shown above and actual performance may differ as a result of end user environment and application.

Files, test reports, and certifications are available upon request:

IES files, photometric layouts, LM-79 reports, L70 TM-21 reports, LM-80 reports, ANSI C-136 3G Vibration, ANSI C62.41.2 Surge Test, RoHS certificate, ASTM B117 3,000 hour salt fog spray test, Ingress Protection certification, UL certifications, etc.

## Photometrics:

**NEPTUNE-40W-30K-T2**

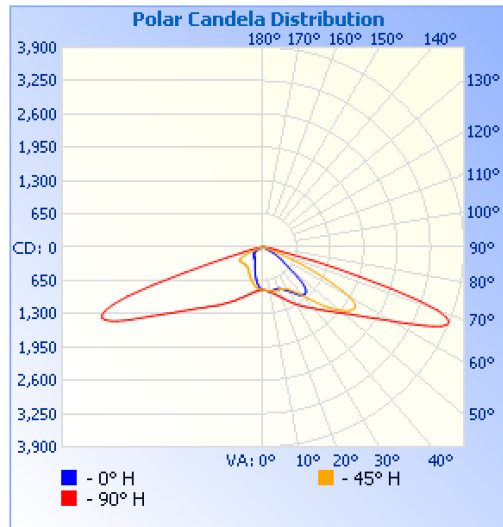

**NEPTUNE-100W-30K-T2**

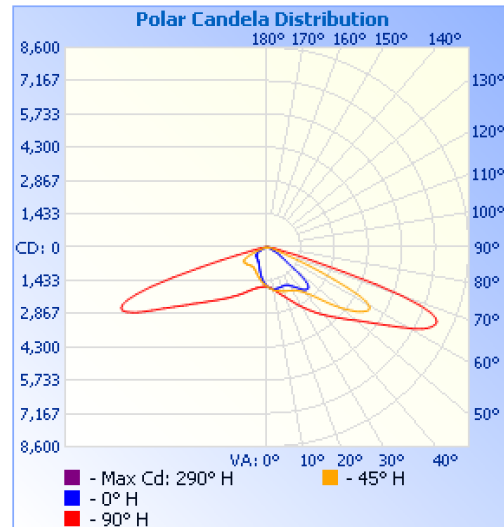

**Illuminance at a Distance**

	Center Beam fc	Beam Width	
8.3ft	12.2 fc	12.3 ft	3.6 ft
16.7ft	3.00 fc	24.8 ft	7.2 ft
25.0ft	1.34 fc	37.2 ft	10.8 ft
33.3ft	0.76 fc	49.5 ft	14.4 ft
41.7ft	0.48 fc	62.0 ft	18.0 ft
50.0ft	0.34 fc	74.3 ft	21.6 ft

■ Vert. Spread: 73.3°  
■ Horiz. Spread: 24.3°

**Illuminance at a Distance**

	Center Beam fc	Beam Width	
8.3ft	24.6 fc	13.7 ft	4.2 ft
16.7ft	6.07 fc	27.6 ft	8.4 ft
25.0ft	2.71 fc	41.3 ft	12.6 ft
33.3ft	1.53 fc	55.0 ft	16.8 ft
41.7ft	0.97 fc	68.8 ft	21.0 ft
50.0ft	0.68 fc	82.5 ft	25.2 ft

■ Vert. Spread: 79.1°  
■ Horiz. Spread: 28.2°

To view complete photometric reports or download IES files - please visit our website [www.AllGreenLightingInc.com](http://www.AllGreenLightingInc.com)

## Ordering Guide:

NEPTUNE-40W	GR	100-277V	30K	T2	SF 2.38"	10kv - DM - 7PCR+SC
<b>Wattage:</b> 25W 40W 65W 80W 100W 120W 150W 180W 240W	<b>Color:</b> GR: Grey (RAL: 7038) BL: Black (RAL:9017) BR: Bronze (RAL:8028) Custom Colors Available	<b>Voltage:</b> 100-277V  347-480V (Available in 65W/120W/ 150W/180W/ 240W only)	<b>CCT:</b> 27K 30K 35K 40K 57K	<b>Beam Type:</b> T2: Type II T3: Type III T4: Type IV T5: Type V	<b>Mount:</b> Slipfitter 2.38" OD or Slipfitter 1.66" OD	<b>Optional Accessories:</b> NPCR: No Photocontrol 3PCR: ANSI 3 Pin Photocell Receptacle 5PCR: ANSI 5 Pin Photocell Receptacle 7PCR: ANSI 7 Pin Photocell Receptacle 3PC: 3 Pin Photocell SC: Shorting Cap MS: Motion Sensor DM: 0-10V dimming (controls by others) 10kv: 10kV Surge Protection 20kv: 20kV Surge Protection NEMA: NEMA Label