

# LED Hi-Bay Retrofit Lamp User Manual



**Before You Begin**

Read These Instructions Completely and Carefully

## WARNING

### Risk of electric shock

- Disconnect electrical power to fixture and follow proper lockout/tag out procedures before installation or maintenance. Contact a qualified electrician for installation.
- This device requires 100V-277VAC input voltage.
- This device requires all ballasts, capacitors, and starters to be bypassed/removed.
- Suitable for use in dry or damp locations only. DO NOT use where directly exposed to liquid, vapor, rain.
- This device is not intended for use with emergency exits.
- This device is not intended for use with dimmers or remote controls.
- This device is suitable for enclosed fixtures, minimum lamp compartment dimensions:  
11.81”(L) x 11.81” (W) x 15.75”(H)
- This device is only available for base up or base down installation.
- **OPERATING TEMPERATURE:** -40° C to 45° C (-40° F to 113° F)

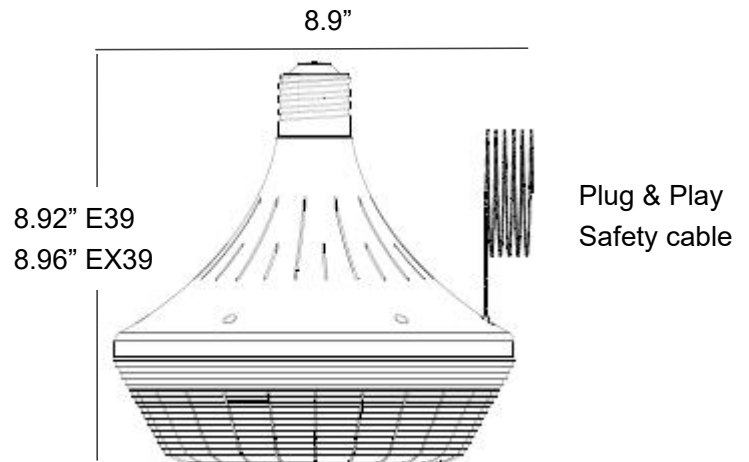

## Replacing HPS/HID Lamp

